

**GENERAL SERVICE GATE, GLOBE & CHECK VALVE RANGE**

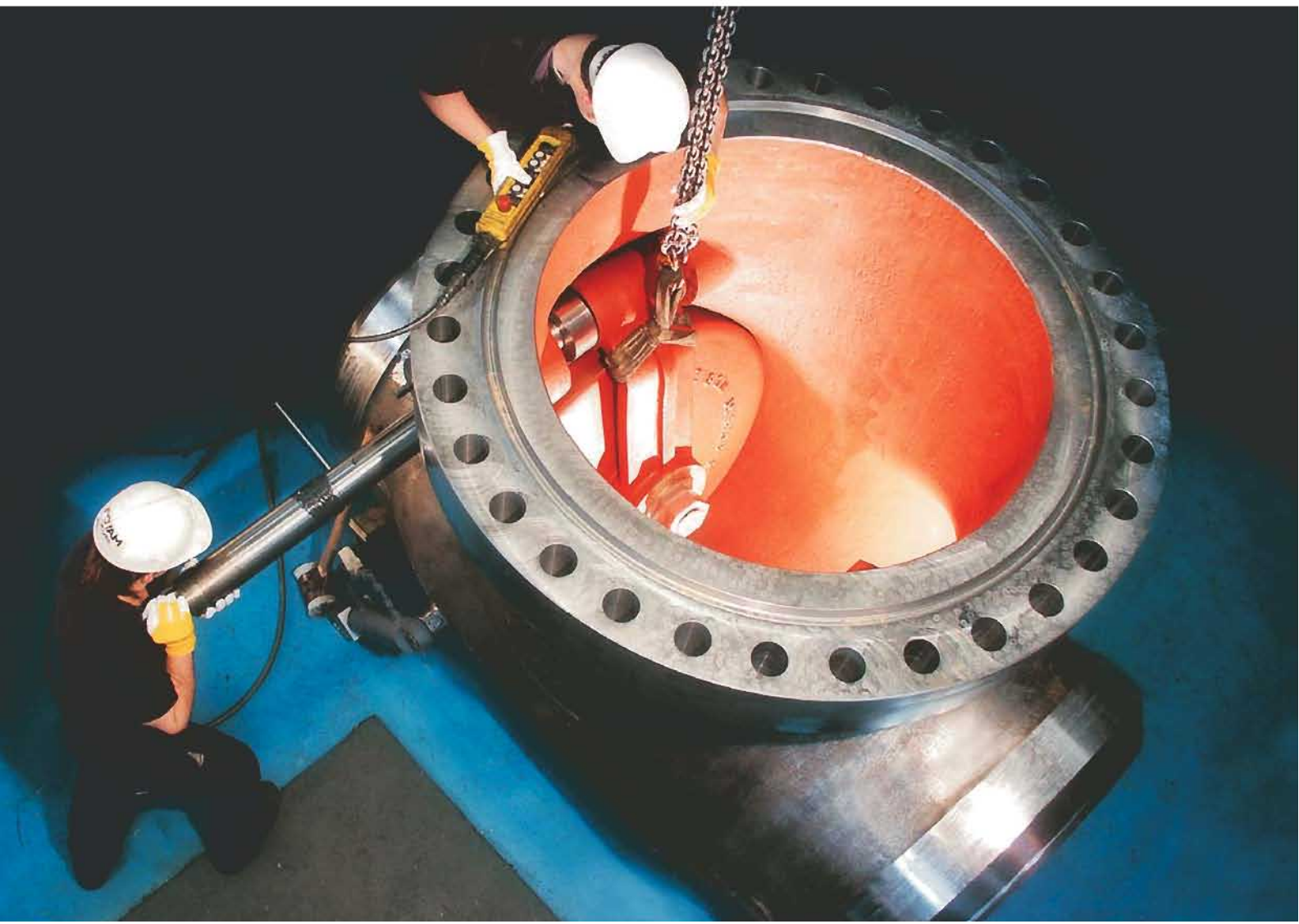



POYAM VALVES is one of the world's largest manufacturers of high specification gate, globe & check valves, recognized as a leader in quality and innovation. Founded 1964, our company leveraged advanced engineering capabilities and innovation-driven focus to continuously expand our offering of high quality- high technology valves.

Today we produce engineered products up to 56" and up to 2500# in a variety of standard and exotic materials such as Titanium, Hastelloy, Incoloy, Inconel, Super Duplex, ....We also can produce the entire range of weld overlays on any kin of base materials for abrasive and corrosive applications.

POYAM Gate, globe & check, valves are installed throughout the world, handling diverse applications in :

## GENERAL SERVICE VALVE RANGE

Power Generation	Elevated Temperatures	Oil & Gas Production/Drilling	Marine
PTA	Geothermal Processes	Petrochemical	Mining
Abrasive & Corrosive Serv.	Hydrofluoric Acid Processing	Pipeline (Natural Gas)	Chemicals
Refinery	Offshore-Platform	Pipeline (Oil/Liquid)	Pharmaceuticals



With our own quality renowned foundry AMPO and long experience in this range of valves, Poyam Valves is able to design and manufacture high technology valves with the best performance and low maintenance cost.

Through our Field Engineering Service (FES) team we provide timely response to customers' needs worldwide: witness and give technical support in commissioning & start up stage, maintenance shut down supervision, troubleshooting and repair service, equipment selection, maintenance and operation trainings....



**GENERAL SERVICE GATE, GLOBE & CHECK VALVES**





## GENERAL SERVICE GATE VALVES

### GATE VALVES BOLTED BONNET

(Also available in pressure seal)

#### STANDARD DESIGN (API 600)

Standards: **API, BS, MSS, ANSI, ASME, ASTM**  
 Classes: **150 lbs up to 2500 Lbs.**  
 Sizes: **2" up to 56"**

Construction: - Bolted bonnet.  
 - Flanged and butt weld ends.  
 - Manual and motor-operated.  
 - Metal seats.

#### CLASS 150 DIMENSIONS IN MILLIMETERS

NO.	1/2"	3/4"	1"	1 1/2"	2"	3"	4"	6"	8"	10"	12"	14"	16"	18"	20"	24"	30"	36"	40"	42"	48"
<b>D</b>	13	20	25	39	52	76	102	152	203	254	305	335	387	432	489	584	737	881	989	1020	1168
<b>H</b>	220	220	272	342	305	443	535	662	769	1001	1159	1773	1962	2206	2407	2793	3425	4190	4553	4628	5140
<b>H'</b>	245	245	308	396	367	530	645	830	985	1277	1487	-	-	-	-	-	-	-	-	-	-
<b>L (RF)</b>	108	117,5	127	165,1	177,8	203,2	228,6	266,7	292,1	330,2	355,6	381	406,4	431,8	457,2	508	609,6	711,2	813	813	914,4
<b>L (BW)</b>	108	117,5	127	165,1	215,9	282,5	304,8	403,4	419,1	457,2	501,7	571,5	609,6	660,4	711,2	812,8	914,4	1016	1143	1143	1292,7
<b>M</b>	160	160	225	225	225	275	325	380	380	400	700	500	500	800	800	600	900	900	800	800	1000
<b>Weight (RF)</b>	5	12	14	19	21	37	59	80	129	220	294	470	605	660	808	1335	2305	3975	5120	5484	7062
<b>Weight (BW)</b>	4	10	12	16	17	32	48	64	110	184	259	431	529	572	710	1241	2208	3793	4877	5233	6337

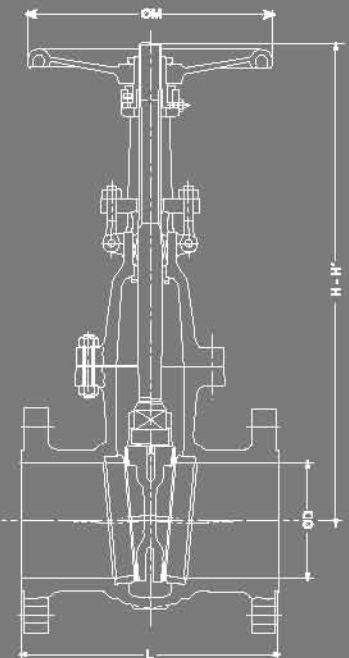

### CLASS 300 DIMENSIONS IN MILLIMETERS

ND.	1/2"	3/4"	1"	1 1/2"	2"	3"	4"	6"	8"	10"	12"	14"	16"	18"	20"	24"	26"	28"	30"	32"	36"
D	13	20	25	40	52	76	102	152	203	254	305	335	385	432	483	584	635	686	737	781	876
H	225	225	267	382	410	500	580	661	905	1034	1195	1839	2051	2373	2526	2865	3207	3287	3506	3506	4258
H'	253	253	304	436	479	588	674	829	1123	1310	1523	-	-	-	-	-	-	-	-	-	-
L (RF)	139,7	154,4	165,1	190,5	215,9	282,4	304,8	403,3	419,1	457,2	501,6	762	838,2	914,4	990,6	1143	1244,6	1346,2	1397	1524	1727,2
L (BW)	139,7	154,4	165,1	190,5	215,9	282,4	304,8	403,3	419,1	457,2	501,6	762	838,2	914,4	990,6	1143	1244,6	1346,2	1397	1524	1727,2
M	160	160	225	225	225	275	380	380	500	500	700	700	700	700	800	800	800	800	900	900	1000
Weight (RF)	7	14	17	25	31	43	83	159	240	352	503	768	1020	1300	1626	2730	3206	4470	4650	4815	6612
Weight (BW)	6	11	14	21	27	39	65	122	182	288	410	643	833	1220	1525	2343	3126	4344	4515	4957	6778

### CLASS 600 DIMENSIONS IN MILLIMETERS

ND.	1/2"	3/4"	1"	1 1/2"	2"	3"	4"	6"	8"	10"	12"	14"	16"	18"	20"	24"	26"	28"	30"
D	13	19	25	38	52	76	102	152	203	248	298	327	375	419	464	559	605	650	700
H	212	223	312	334	335	533	637	812	1087	1548	1807	1916	2127	2331	2564	2724	3075	3075	3692
H'	237	247	349	386	400	639	759	995	1331	-	-	-	-	-	-	-	-	-	-
L (RF)	165,1	190,5	215,9	241,3	292,1	355,6	431,8	558,8	660,4	787,4	838,2	889	990,6	1092,2	1193,8	1397	1447,8	1549,4	1651
L (BW)	165,1	190,5	215,9	241,3	292,1	355,6	431,8	558,8	660,4	787,4	838,2	889	990,6	1092,2	1193,8	1397	1447,8	1549,4	1651
M	160	160	225	225	325	325	380	500	600	800	600	700	800	800	800	900	1000	1000	1000
Weight (RF)	12	18	23	33	51	72	135	275	454	698	1055	1387	1902	2124	2664	3742	4815	6105	6790
Weight (BW)	9	14	19	29	46	56	111	221	371	588	935	1215	1735	1975	2437	3262	4527	5708	6535

### CLASS 900 DIMENSIONS IN MILLIMETERS

ND.	1/2"	3/4"	1"	1 1/2"	2"	3"	4"	6"	8"	10"	12"	14"	16"	18"	20"	24"
D	13	19	25	32	48	76	102	147	191	248	283	311	356	400	445	533
H	261	291	301	319	538	630	706	1185	1403	1605	1793	1886	2226	2341	2577	2819
H'	289	322	338	368	600	728	824	-	-	-	-	-	-	-	-	-
L (RF)	165,1	190,5	215,9	241,3	368,3	381	457,2	609,6	736,6	787,4	965,2	1028,7	1130,3	1219,2	1320,8	1397
L (BW)					368,3	381	457,2	609,6	736,6	787,4	965,2	1028,7	1130,3	1219,2	1320,8	1397
M	160	225	225	225	325	380	380	700	500	600	700	700	800	700	700	800
Weight (RF)	17	27	34	46	83	121	186	372	653	980	1335	1750	2130	3615	4534	6721
Weight (BW)	12	22	29	39	73	97	160	326	591	798	1209	1550	1785	3307	4132	6270

### CLASS 1500 DIMENSIONS IN MILLIMETERS

ND.	1/2"	3/4"	1"	1 1/2"	2"	3"	4"	6"	8"	10"	12"	14"	16"
D	13	19	25	32	48	70	92	137	178	222	264	289	330
H	261	291	301	319	401	654	928	1101	1457	1696	1896	1995	2213
H'	289	322	338	368	474	744	-	-	-	-	-	-	-
L (RF)	165,1	190,5	215,9	241,3	368,3	469,9	546,1	704,85	831,85	990,6	1130,3	1257,3	1384,3
L (BW)					368,3	469,9	546,1	704,85	831,85	990,6	1130,3	1257,3	1384,3
M	160	225	225	225	325	380	500	700	700	600	800	800	900
Weight (RF)	17	27	34	46	83	190	294	575	1104	2020	2951	3350	3687
Weight (BW)	12	22	29	39	73	142	231	459	960	1815	2721	3087	3361

### CLASS 2500 DIMENSIONS IN MILLIMETERS

ND.	2"	3"	4"	6"	8"	10"
D	44	58	73	111	146	184
H	532	667	1290	1445	1603	1957
H'	601	743	-	-	-	-
L (RF)	450,8	577,85	673,1	914,4	1022,35	1270
L (BW)	450,8	577,85	673,1	914,4	1022,35	1270
M	325	380	500	600	600	800
Weight (RF)	143	261	371	668	1337	2428
Weight (BW)	126	207	291	571	1172	2163





## GATE VALVES BOLTED BONNET

(Also available in pressure seal)

### LIGHT PATTERN DESIGN (ASME B16 - 34)

Standards: **API, BS, MSS, ANSI, ASME, ASTM**  
 Classes: **150 lbs up to 2500 lbs.**  
 Sizes: **2" up to 56"**

- Construction:
- Bolted bonnet.
  - Flanged and butt weld ends.
  - Manual and motor-operated.
  - Metal seats.



### CLASS 150 DIMENSIONS IN MILLIMETERS

ND.	2"-3	3"-3	4"-3	6"-3	8"-3	10"-3	12"-3
<b>D</b>	52	76	102	152	203	254	305
<b>H</b>	281	350	417	558	731	887	1097
<b>H'</b>	344	438	532	724	851	1161	1404
<b>L (RF)</b>	177,8	203,2	228,6	266,7	292,1	330,2	355,6
<b>L (BW)</b>	215,9	282,5	304,8	403,4	419,1	457,2	501,7
<b>M</b>	225	225	275	325	380	380	400
<b>Weight (RF)</b>	15	24	39	63	100	158	238
<b>Weight (BW)</b>	11	19	28	47	81	122	203

### CLASS 300 DIMENSIONS IN MILLIMETERS

ND.	2"-3	3"-3	4"-3	6"-3	8"-3	10"-3	12"-3
<b>D</b>	52	76	102	152	203	254	305
<b>H</b>	310	370	424	610	795	958	1119
<b>H'</b>	373	459	538	778	1015	1232	1446
<b>L (RF)</b>	215,9	282,4	304,8	403,3	419,1	457,2	501,6
<b>L (BW)</b>	215,9	282,4	304,8	403,3	419,1	457,2	501,6
<b>M</b>	225	225	275	380	380	500	500
<b>Weight (RF)</b>	21	39	78	110	180	285	433
<b>Weight (BW)</b>	17	35	60	73	122	221	338

**GENERAL SERVICE GLOBE VALVES**



# GLOBE VALVES BOLTED BONNET

(Also available in pressure seal)

Standards: **API, BS, MSS, ANSI, ASME, ASTM**  
 Classes: **150 lbs up to 2500 lbs.**  
 Sizes: **2" up to 56"**

- Construction:
- Bolted bonnet.
  - Flanged and butt weld ends.
  - Manual and motor-operated.
  - Metal seats.
  - Throttling Service Globe valves.

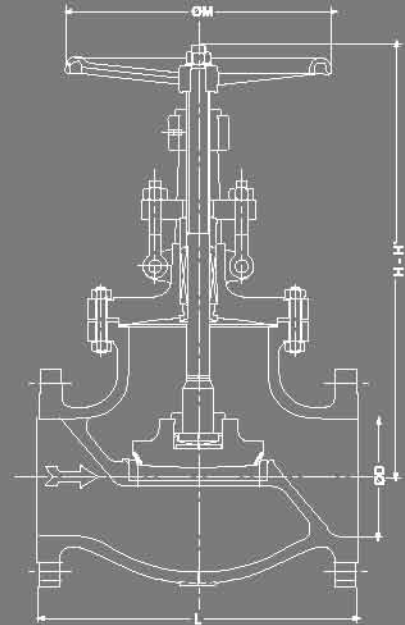

## CLASS 150 DIMENSIONS IN MILLIMETERS

ND.	1/2"	3/4"	1"	1 1/2"	2"	3"	4"	6"	8"	10"	12"	14"	16"	18"	20"	24"
D	13	19	25	38	52	76	102	152	203	254	305	336	387	432	489	590
H	217	230	245	288	332	405	478	677	969	1028	1285	1419	1565	1795	1883	2100
H'	227	243	260	308	377	435	534	742	-	-	-	-	-	-	-	-
L (RF)	107,9	117,5	127	165,1	203,2	241,3	292,1	406,4	495,3	622,3	698,5	787,4	914,4	1041,4	1168,4	1295,4
L (BW)	107,9	117,5	127	165,1	203,2	241,3	292,1	406,4	495,3	622,3	698,5	787,4	914,4	1041,4	1168,4	1295,4
M	160	160	160	200	225	325	325	500	500	500	600	600	600	800	800	1000
Weight (RF)	6	8	9	14	23	38	60	99	175	271	412	534	738	997	1396	2510
Weight (BW)	5	7	8	11	18	31	49	83	157	256	379	488	671	906	1267	2185

## CLASS 300 DIMENSIONS IN MILLIMETERS

ND.	1/2"	3/4"	1"	1 1/2"	2"	3"	4"	6"	8"	10"	12"	14"	16"
D	13	19	25	38	52	76	102	152	203	254	304	336	387
H	217	281	255	285	402	506	535	939	1101	1324	1421	1656	1574
H'	227	306	270	305	440	536	597	-	-	-	-	-	-
L (RF)	152,4	177,8	203,2	228,6	266,7	317,5	355,6	444,5	558,8	622,3	711,2	787,4	914,4
L (BW)	152,4	177,8	203,2	228,6	266,7	317,5	355,6	444,5	558,8	622,3	711,2	787,4	914,4
M	160	160	160	200	225	325	325	500	600	700	700	700	800
Weight (RF)	10	18	20	23	35	60	90	175	258	390	562	766	915
Weight (BW)	8	15	16	19	28	42	73	142	211	322	523	692	807

## CLASS 600 DIMENSIONS IN MILLIMETERS

ND.	1/2"	3/4"	1"	1 1/2"	2"	3"	4"	6"	8"	10"	12"
D	13	19	25	38	52	76	102	152	200	248	298
H	251	280	285	292	464	546	761	1127	1302	1515	1549
H'	271	305	309	312	495	576	801	-	-	-	-
L (RF)	165,1	190,5	215,9	241,3	292,1	355,6	431,8	558,8	660,5	787,4	838,2
L (BW)	165,1	190,5	215,9	241,3	292,1	355,6	431,8	558,8	660,5	787,4	838,2
M	160	160	200	200	225	325	500	500	500	800	800
Weight (RF)	13	17	22	26	48	76	138	260	495	815	826
Weight (BW)	11	14	18	22	36	60	103	210	448	770	791





### CLASS 900 DIMENSIONS IN MILLIMETERS

ND.	1/2"	3/4"	1"	1 1/2"	2"	3"	4"κ	6"κ	8"κ	10"κ	12"κ
<b>D</b>	13	17	22	35	48	76	98	146	190	238	283
<b>H</b>	261	281	323	323	542	604	1007	1234	1511	1762	1860
<b>H'</b>	280	303	337	337	577	644	-	-	-	-	-
<b>L (RF)</b>	215,9	228,6	254	304,8	368,3	381	457,2	609,6	736,6	838,2	965,2
<b>L (BW)</b>	215,9	228,6	254	304,8	368,3	381	457,2	609,6	736,6	838,2	965,2
<b>M</b>	160	160	200	200	325	325	400	700	800	1000	1000
<b>Weight (RF)</b>	-	-	-	-	82	109	187	342	827	1546	1812
<b>Weight (BW)</b>	-	-	-	-	75	124	165	315	752	1459	1693

### CLASS 1500 DIMENSIONS IN MILLIMETERS

ND.	2"	3"κ	4"κ	6"κ	8"κ	10"κ	12"κ
<b>D</b>	48	73	92	137	178	222	264
<b>H</b>	542	952	1070	1366	1671	1871	1987
<b>H'</b>	577	-	-	-	-	-	-
<b>L (RF)</b>	368,3	469,9	546,1	704,85	831,85	990,6	1130,3
<b>L (BW)</b>	368,3	469,9	546,1	704,85	831,85	990,6	1130,3
<b>M</b>	325	600	600	900	1000	1000	1000
<b>Weight (RF)</b>	82	148	354	616	1115	2278	2720
<b>Weight (BW)</b>	75	167	318	634	1026	2163	2582

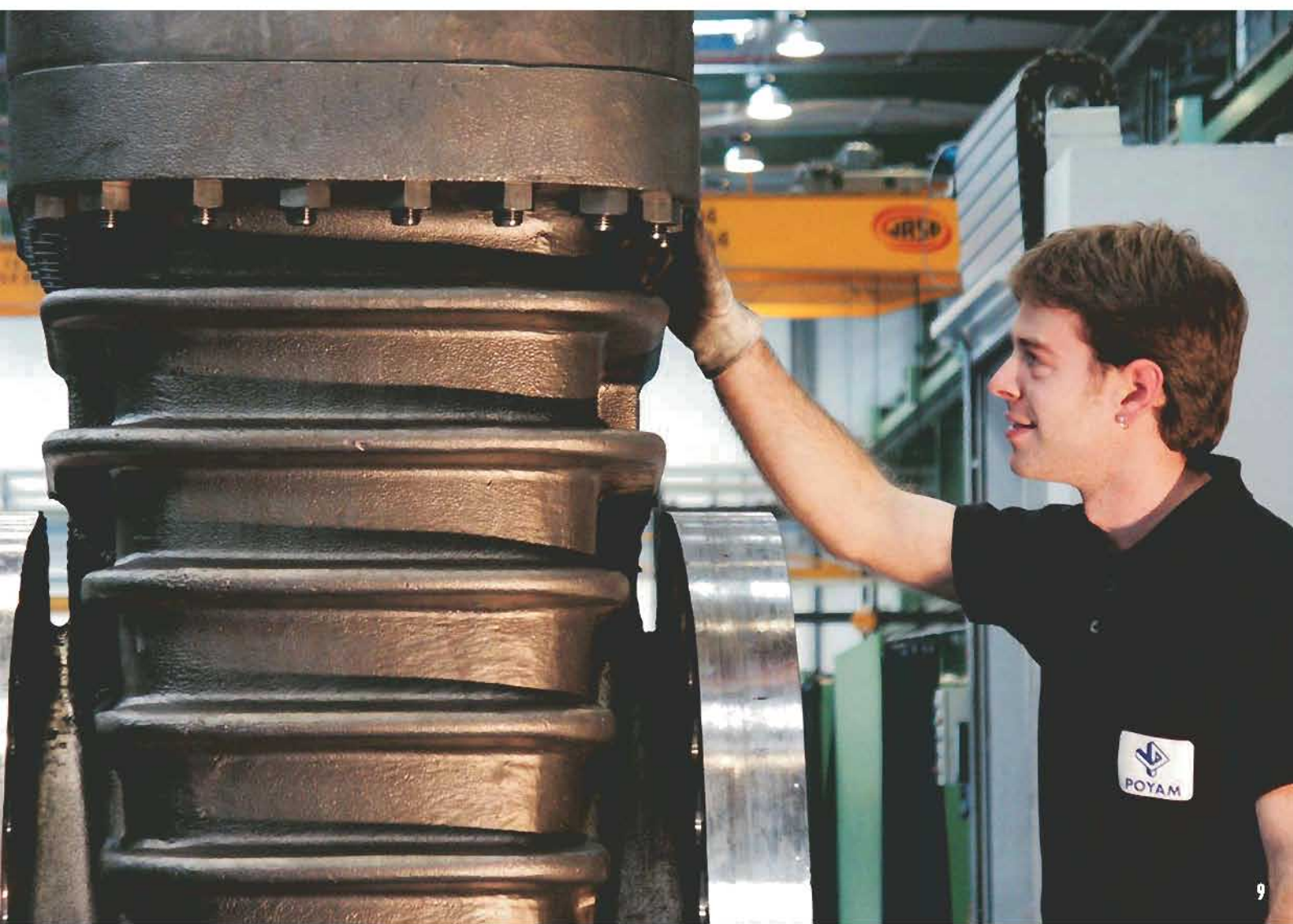
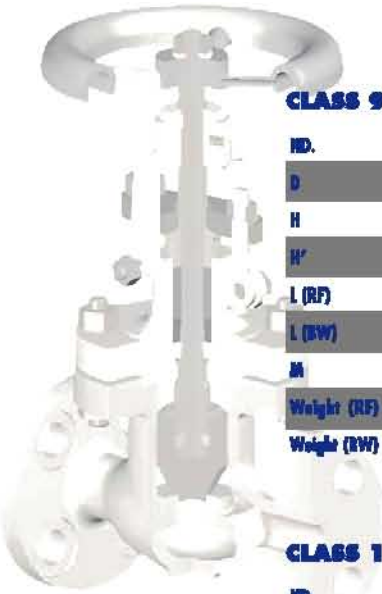

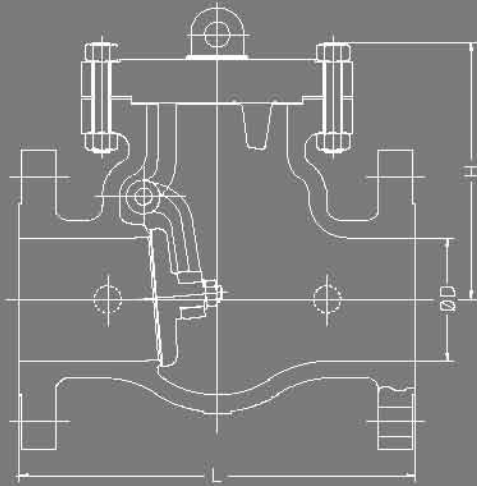

## CHECK VALVES BOLTED BONNET

(Also available in pressure seal)

Standards: API, BS, MSS, ANSI, ASME, ASTM  
 Classes: 150 lbs up to 2500 Lbs.  
 Sizes: 2" up to 56"

Construction: - Bolted bonnet.  
 - Swing Check type/ Lift Check type.  
 - Flanged and butt weld ends.  
 - Metal seats.

### CLASS 150 DIMENSIONS IN MILLIMETERS

ND.	1/2"	3/4"	1"	1 1/2"	2"	3"	4"	6"	8"	10"	12"	14"	16"	18"	20"	24"	30"	32"	36"	40"	42"
L (BW)	108	177,3	127	165,1	203,2	241,3	292,1	355,6	495,3	622,3	698,5	787,4	863,6	977,9	977,9	1295,4	1524	1850	2050	2146	2250
L (RF)	108	177,3	127	165,1	203,2	241,3	292,1	355,6	495,3	622,3	698,5	787,4	863,6	977,9	977,9	1295,4	1524	1850	2050	2146	2250
DH	15	20	25	38	52	76	102	152	203	254	305	335	387	438	489	590	737	737	876	932	1020
H	105	108	112	126	143	186	210	247	304	331	410	459	499	552	572	670	800	897	995	1021	1291
Weight (Kg) BW	8	9	10	11	13	20	30	63	114	196	271	423	519	590	733	1324	2240	3574	4581	6830	7798
Weight (Kg) RF	10	11	12	13	16	27	43	71	128	232	326	460	576	660	808	1404	2330	2814	5818	8674	9904

### CLASS 300 DIMENSIONS IN MILLIMETERS

ND.	1/2"	3/4"	1"	1 1/2"	2"	3"	4"	6"	8"	10"	12"	14"	16"	18"	20"	24"	30"	32"	36"	40"	42"
L (BW)	152,4	177,8	215,9	241,3	266,7	317,5	355,6	444,5	533,4	622,3	711,2	838,2	863,6	978	1016	1346,2	1593,9	1524	1727,2	1930,4	1981,2
L (RF)	152,4	177,8	215,9	241,3	266,7	317,5	355,6	444,5	533,4	622,3	711,2	838,2	863,6	978	1016	1346,2	1593,9	1524	1727,2	1930,4	1981,2
DH	15	20	28	38	52	76	102	152	203	254	304	335	387	432	483	584	737	737	876	932	1020
H	105	108	112	134	152	184	222	275	328	392	451	487	552	591	622	721	860	973	1134	1154	1471
Weight (Kg) BW	9	10	11	12	17	30	42	92	150	265	327	532	727	1030	1127	1933	3005	4181	5299	7248	8187
Weight (Kg) RF	11	12	13	14	24	46	62	125	220	320	446	612	572	1150	1252	2063	3150	5310	6730	9205	10398

### CLASS 600 DIMENSIONS IN MILLIMETERS

ND.	1/2"	3/4"	1"	1 1/2"	2"	3"	4"	6"	8"	10"	12"	14"	16"	18"	20"	24"	28"	30"	32"	36"	40"	42"
L (BW)	165,1	190,5	215,9	241,3	292,1	355,6	431,8	558,8	660,4	787,4	838,2	889	990,6	1092,2	1193,8	1397	1600,2	1651	1778	2082,8	2132	2438,4
L (RF)	165,1	190,5	215,9	241,3	292,1	355,6	431,8	558,8	660,4	787,4	838,2	889	990,6	1092,2	1193,8	1397	1600,2	1651	1778	2082,8	2132	2438,4
DH	15	20	26	38	52	76	101	152	203	248	298	327	375	419	489	559	695	695	737	838	932	1020
H	113	118	122	136	198	217	279	366	424	522	564	593	624	705	784	839	1088	1088	1088	1232	1260	1563
Weight (Kg) BW	11	12	13	20	26	44	78	162	310	508	705	972	1365	1550	2371	2960	4662	5615	7015	9622	13165	14532
Weight (Kg) RF	13	14	16	24	32	60	103	202	335	622	830	1107	1505	1903	2696	3307	5191	5790	8910	12220	16720	18581



**CLASS 900 DIMENSIONS IN MILLIMETERS**

ND.	1/2"	3/4"	1"	1 1/2"	2"	3"	4"	6"	8"	10"	12"	14"	16"	32"	36"
L (BW)	215,9	228,6	254	304,8	368,3	381	457,2	609,6	736,6	838,2	965,2	1028,7	1130,3	2019,3	2235,2
L (RF)	215,9	228,6	254	304,8	368,3	381	457,2	609,6	736,6	838,2	965,2	1028,7	1130,3	2019,3	2235,2
DH	13	18	25	35	50	73	102	147	191	238	283	311	356	762	818
H	113	118	122	167	237	265	317	402	474	557	597	640	678	1010	1492
Weight (Kg) BW	18	20	25	36	66	79	128	241	470	760	1202	1417	1708	9075	11400
Weight (Kg) RF	23	26	31	42	74	94	158	302	505	880	1360	1742	2089	11525	14576

**CLASS 1500 DIMENSIONS IN MILLIMETERS**

ND.	1/2"	3/4"	1"	1 1/2"	2"	3"	4"	6"	8"	10"	12"
L (BW)	215,9	228,6	254	304,8	368,3	469,9	546,1	704,9	831,9	990,6	1130,3
L (RF)	215,9	228,6	254	304,8	368,3	469,9	546,1	704,9	831,9	990,6	1130,3
DH	13	18	25	35	48	70	92	137	178	222	264
H	113	118	122	167	237	296	342	469	553	643	755
Weight (Kg) BW	18	20	25	36	66	117	182	409	662	1308	2192
Weight (Kg) RF	23	26	31	42	74	135	226	515	898	1588	2497

**CLASS 2500 DIMENSIONS IN MILLIMETERS**

ND.	1/2"	3/4"	1"	1 1/2"	2"	3"	4"	6"
L (BW)	263,6	273	307,8	384	450,9	577,9	673,1	914,4
L (RF)	263,6	273	307,8	384	450,9	577,9	673,1	914,4
DH	11	15	19	34	52	57	73	111
H	140	147	164	217	290	366	426	582
Weight (Kg) BW	25	38	48	57	89	202	307	528
Weight (Kg) RF	32	43	54	65	110	224	331	619





*"OUR FOUNDRY WORKS TOGETHER WITH OUR R+D+I TEAM TO CREATE NEW DEVELOPMENTS AND DESIGNS, A KEY FACTOR IN ENABLING POYAM TO CONTROL THE WHOLE PROCESS, FROM START TO FINISH."*

## OUR FOUNDRY, AMPO

Our own foundry AMPO is fully in line with POYAM manufacturing processes, providing us with the best quality castings and service.

Cast materials are produced under strict quality controls at the AMPO foundry. Ongoing control is the key to our quality and success, starting with castings from one of the world's leading valve foundries, AMPO, through to a product finished and tested to any specification, all within our own facilities.

HOMOLOGATIONS / CERTIFICATIONS: ISO 9002. TÜV. LLOYD'S. BUREAU VERITAS. NKK.



**CARBON STEEL FOR GENERAL USE**  
e.g.: WCB, WCC, 1.0619...

**CARBON STEEL FOR LOW TEMPERATURE**  
e.g.: LCB, LCC...

**ALLOY STEEL**  
e.g.: WC1, WC6, WC9, C5, C12...

**ALLOY STEEL FOR LOW TEMPERATURE**  
e.g.: LC1, LC2, LC3,...

**MARTENSITIC STEEL AND FERRITIC MARTENSITE FOR GENERAL SERVICE AND LOW TEMPERATURE**  
e.g.: CA15, CA6NM, 1.4008...

**AUSTENITIC STAINLESS STEEL FOR GENERAL USE, LOW TEMPERATURE**  
e.g.: CF8, CF8M, CF8C, CF3, CF3C, CF3M, 1.4308, 1.4408, 1.4552...

**SUPERAUSTENITIC ALLOYS**  
e.g.: CN7M, CK3MCuN, 254 SMO, 654 SMO...

**DUPLEX ALLOYS**  
e.g.: S31803, S32760, A890Gr4A, A890Gr5A, A890Gr6A, CD4MCu...

**NICKEL BASE ALLOYS**  
e.g.: INCOLOY 825, MONEL 400, INCONEL 625, CW-6MC, CW-12MW...

*"INTERNAL WELD OVERLAY OPTIONS FOR ABRASIVE AND/OR CORROSION APPLICATIONS ARE AVAILABLE."*

## **INTERNAL WELD OVERLAY TECHNOLOGIES**

Poyam Valves solid commitment to high performance and top quality products provide the best welding technology and solutions for any kind of welding needs:

1- Our advanced technologies and high productivity allows Poyam Valves to produce the entire range of weld overlays on any kind of base materials in the shortest turn around times using exotic materials.

2- High quality deposits of Stellite 6 and other hardfacing alloys are assured by the use of the following state of the art technology: controlled preheating, automatic Plasma Arc hardfacing equipment and a controlled cooling process.



*"COST SAVING ALTERNATIVES FOR SOLID EXOTIC MATERIAL REQUIREMENTS."*

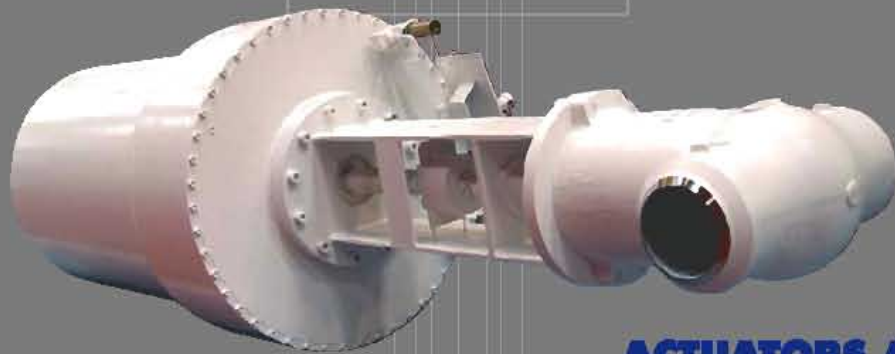

## ACTUATORS AND CONTROLS

Electric Actuators - Pneumatic Actuators - Hydraulic Actuators - Manual Gear Boxes -  
Side-mounted hand wheels - Positioners for control service - Interlocks - Limit Switches

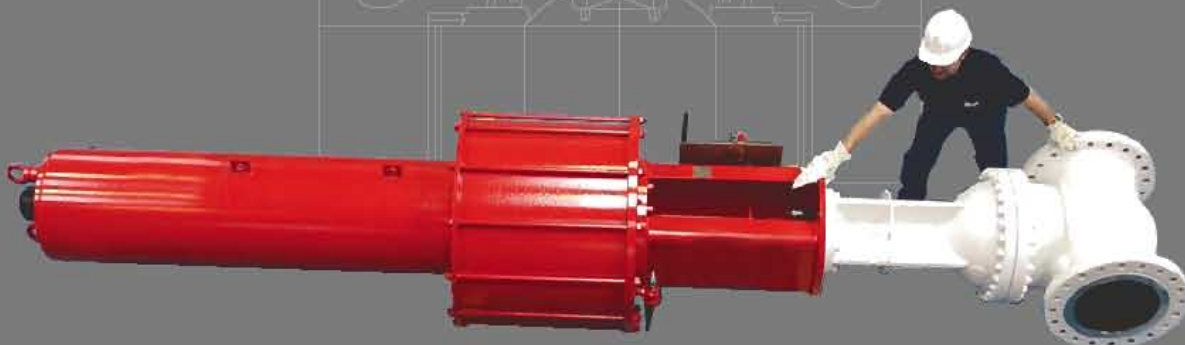
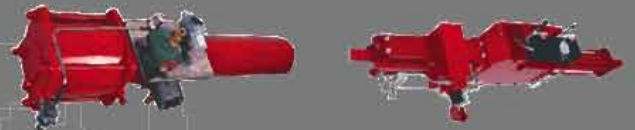

## FIELD ENGINEERING SERVICE



*"THROUGH OUR FIELD ENGINEERING SERVICE (FES) TEAM WE PROVIDE TIMELY RESPONSE TO CUSTOMER NEEDS WORLDWIDE: WITNESS AND TECHNICAL SUPPORT IN COMMISSIONING & START UP STAGE, MAINTENANCE SHUT DOWN SUPERVISION, TROUBLESHOOTING AND REPAIR SERVICE, EQUIPMENT SELECTION, MAINTENANCE AND OPERATION TRAINING..."*

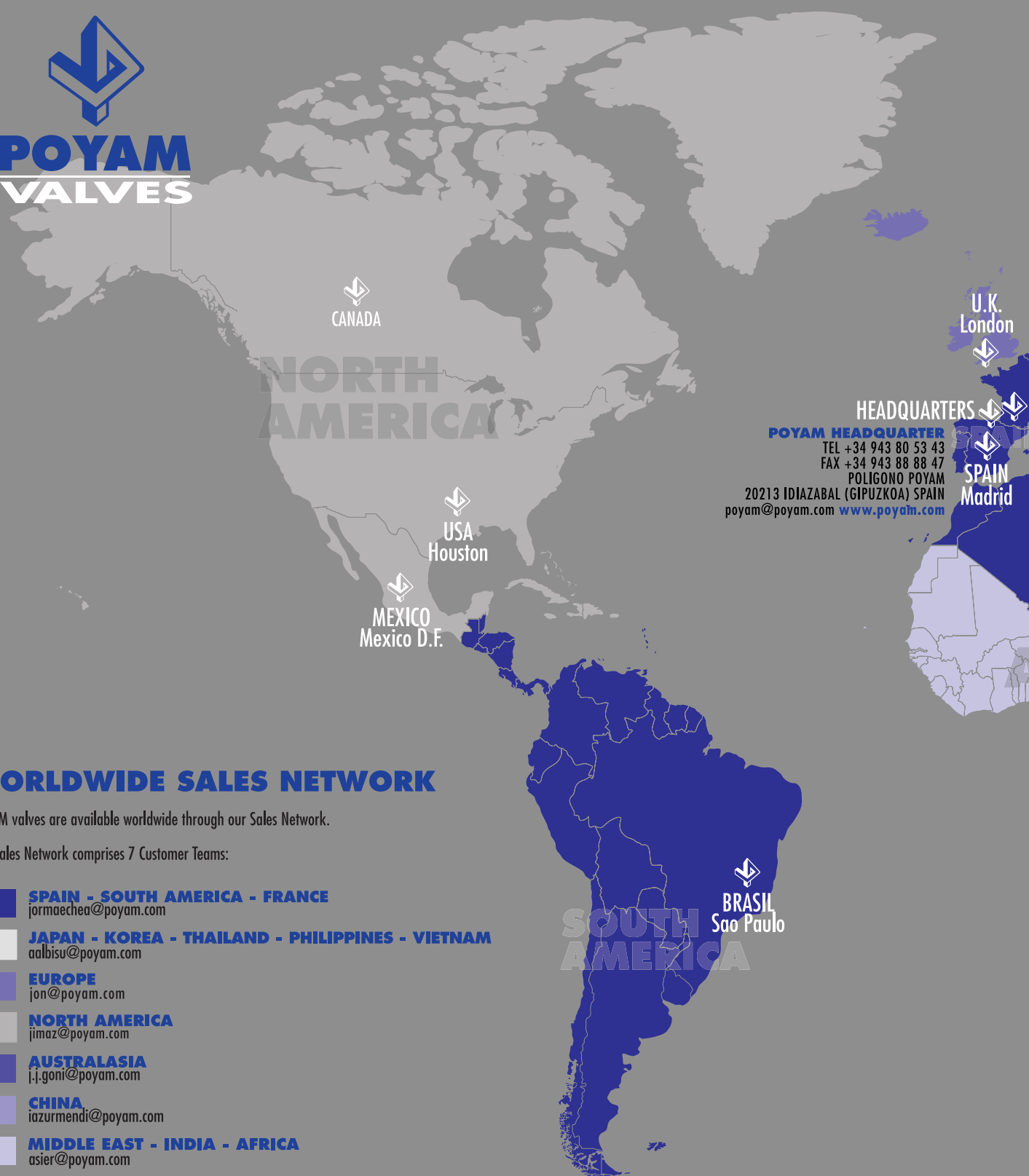

**HEADQUARTERS**  
**POYAM HEADQUARTER**  
 TEL +34 943 80 53 43  
 FAX +34 943 88 88 47  
 POLIGONO POYAM  
 20213 IDIAZABAL (GIPUZKOA) SPAIN  
 poyam@poyam.com [www.poyam.com](http://www.poyam.com)

## WORLDWIDE SALES NETWORK

POYAM valves are available worldwide through our Sales Network.

Our Sales Network comprises 7 Customer Teams:

- SPAIN - SOUTH AMERICA - FRANCE**  
jormaechea@poyam.com
- JAPAN - KOREA - THAILAND - PHILIPPINES - VIETNAM**  
aalbisu@poyam.com
- EUROPE**  
jon@poyam.com
- NORTH AMERICA**  
jimaz@poyam.com
- AUSTRALASIA**  
j.j.goni@poyam.com
- CHINA**  
iazurmendi@poyam.com
- MIDDLE EAST - INDIA - AFRICA**  
asier@poyam.com



### FACTORY & HEADQUARTERS

90 km east of Bilbao, 45 km south of San Sebastian, 70 km south of the French border.

POYAM VALVES is situated in Idiazabal, a town in the north of Spain, in an area with a deeply-rooted industrial tradition called THE BASQUE COUNTRY. Idiazabal is just 1 hour's drive from BILBAO (International Airport) and at these distances from other important places:



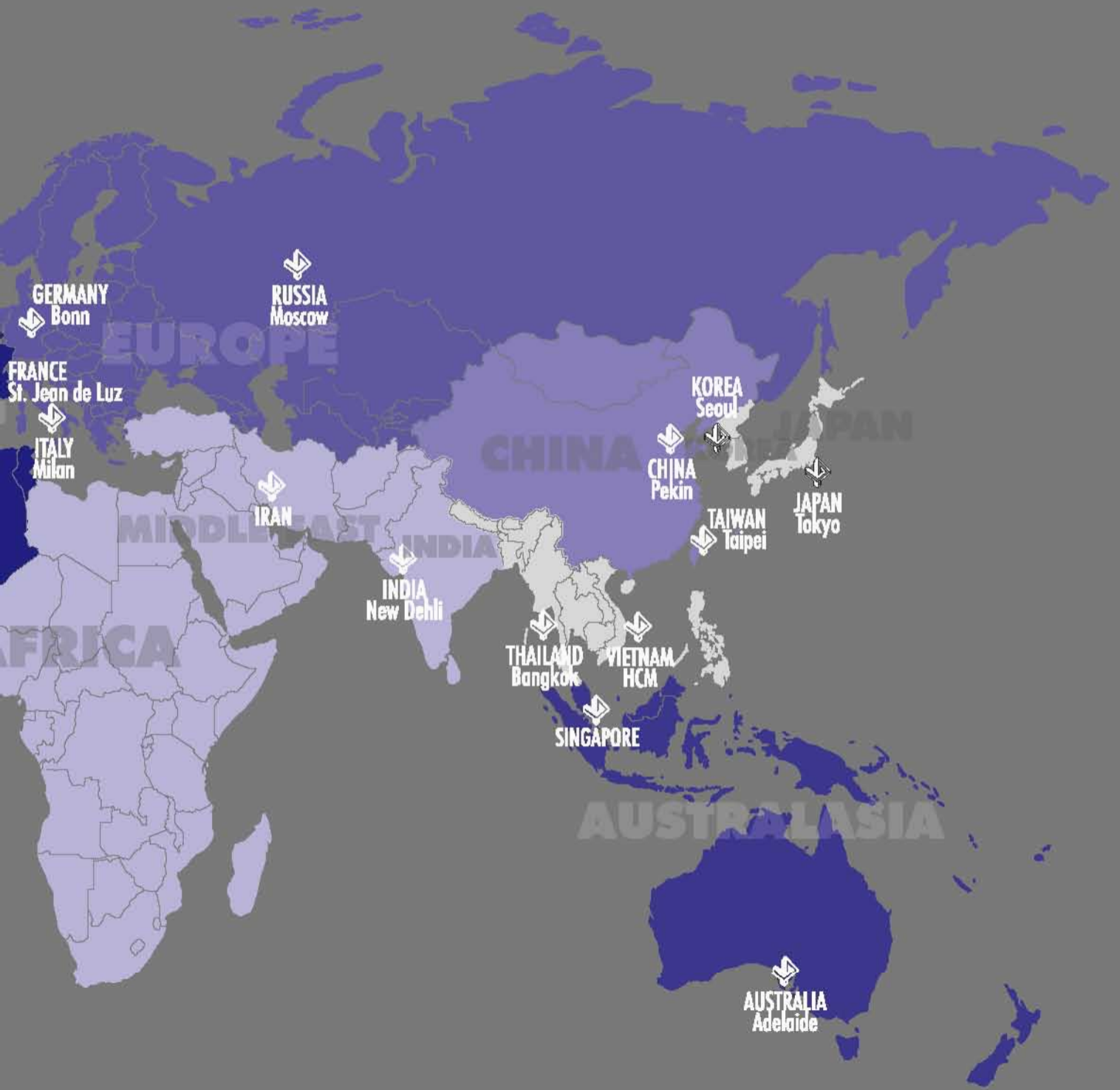

[WWW.POYAM.COM](http://WWW.POYAM.COM)



*POYAM IS THE WORLDS LEADING  
MANUFACTURER OF GENERAL SERVICE AND  
CRYOGENIC SERVICE BALL, GATE , GLOBE  
AND CHECK VALVES*





## **ATTENTION AND SERVICE**

POYAM VALVES is the most efficient partnership at each stage of your project, we have more than 35 years' experience worldwide supplying high-tech, quality products and best service.

*"IN TUNE WITH CUSTOMERS,  
BECAUSE CUSTOMER SATISFACTION  
IS POYAM SATISFACTION"*



**AMPO S.Coop**



AMPO, S.COOP. - POYAM VALVES TEL. +34 943 80 53 43 FAX +34 943 88 88 47 POLIGONO INDUSTRIAL POYAM 20213 IDIAZABAL GIPUZKOA SPAIN [WWW.POYAM.COM](http://WWW.POYAM.COM)

AMPO S.COOP. - IIF 1-20077090 INSCRITA EN EL REGISTRO DE COOPERATIVAS DE EUSKADI N° 86 3 229

publi web